

Eaton SB58901BAL

Catalog Number: SB58901BAL

Eaton B-Line series open frame racks, Aluminum, 3/8"-16 mounting hardware, (2) RMUs of mounting space, Aluminum - brushed, Two-post network equipment rack guard rail, Includes 3/8"-16 mounting hardware, Used with 19" racks

General specifications

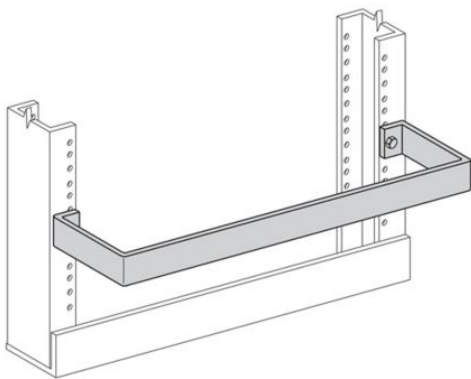

| | |
|--------------------------------------|----------------------|
| Product Name | Catalog Number |
| Eaton B-Line series open frame racks | SB58901BAL |
| UPC | Product Length/Depth |
| 799038029762 | 5.25 in |
| Product Height | Product Width |
| 2 in | 19 in |
| Product Weight | Certifications |
| 1.6 lb | Not Applicable |

Product specifications

Special features

(2) RMUs of mounting space

Model

Two-post network equipment rack guard rail

Material

Aluminum

Finish

Brushed aluminum

Resources

Brochures

[RCM and RCM+ brochure](#)

Specifications and datasheets

[Eaton Specification Sheet - SB58901BAL](#)



Eaton Corporation plc
Eaton House
30 Pembroke Road
Dublin 4, Ireland
Eaton.com
© 2023 Eaton. All Rights Reserved.

Eaton is a registered trademark.

All other trademarks are property of their respective owners.



[Eaton.com/socialmedia](https://www.eaton.com/socialmedia)